



# INSTALLATION INSTRUCTIONS

## DRAWERS #145

Please read and fill out the enclosed warranty registration card to activate your warranty.

### SHIPMENT CONTENTS

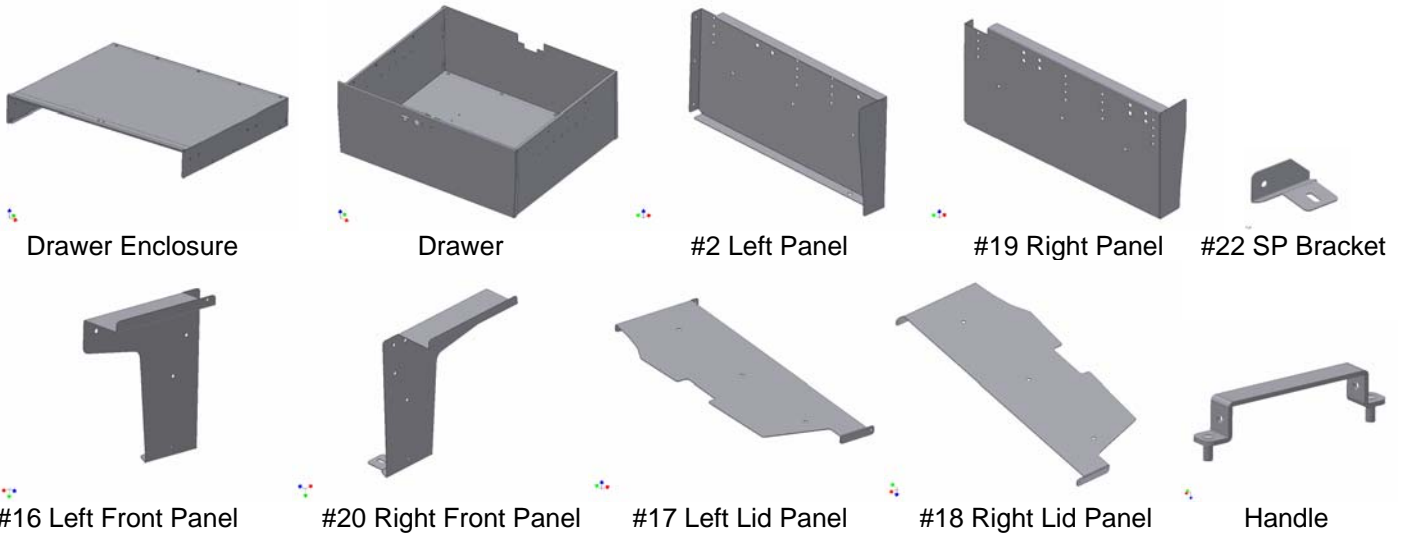

### HARDWARE PACKAGE

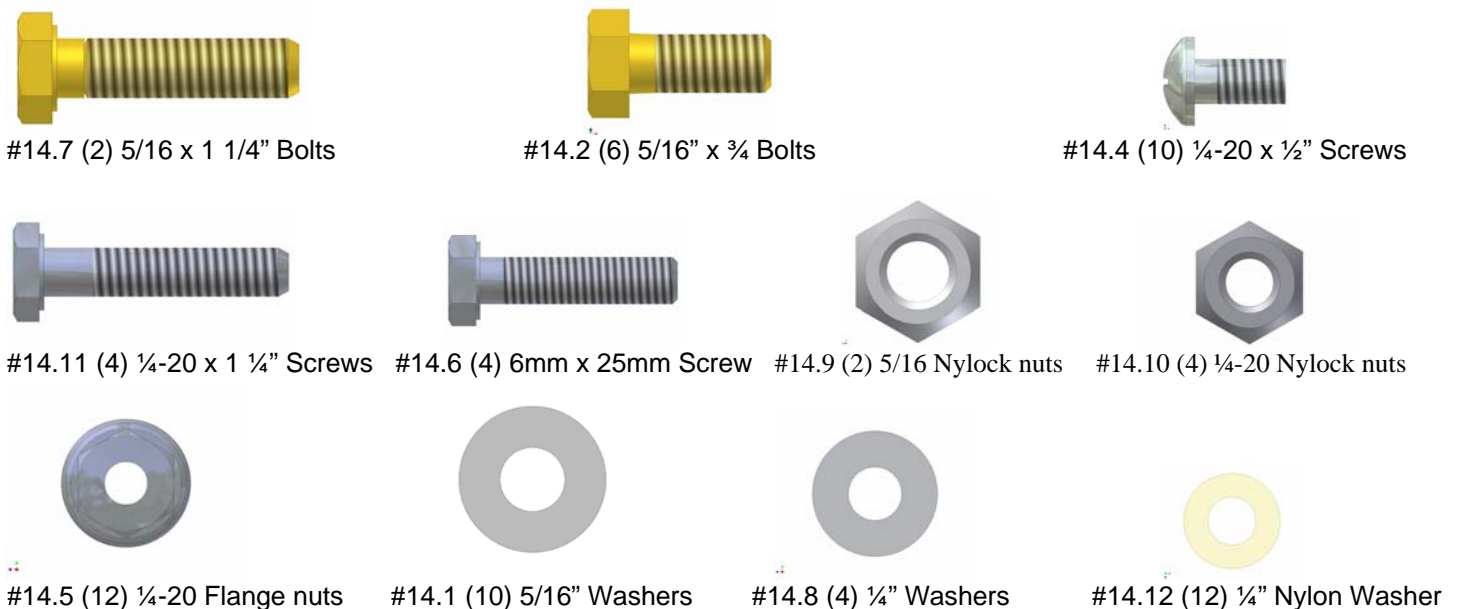

### TOOLS REQUIRED

- 7/16" Wrench
- 10MM Socket & Ratchet
- 1/2" Wrench & Socket
- Regular flat blade screwdriver
- Phillips head screwdriver
- Only required for optional security step - Drill with a 3/8" bit. (A 1/4" bit would be useful to make a pilot hole)

# INSTALLATION

PLEASE READ ALL SAFETY WARNINGS AND INSTRUCTIONS THOROUGHLY BEFORE STARTING INSTALL

***IMPORTANT!*** If the jack is left in the original location it is difficult but possible to get to when the drawer is installed. It is imperative that everyone who may need to use the jack becomes familiar with the procedure for removing it before installing the drawer. Once the drawer is installed it will not be possible to see the jack when removing it and will have to be done blindly from memory. If anyone who will need to access the jack will not be able to blindly remove it for use it should be relocated inside the drawer or another secure location. Do not store it or any other heavy objects in the storage under the side flaps they are not designed to retain items in an accident.

1. Start by folding the rear seat down in the FJ and removing the carpet
2. Remove the (4) original 6mm screws which are holding the tie down loops to the rear deck of the FJ. There are (2) black plastic caps on the rear (2) 6mm screws which can be popped off with a regular screwdriver. Behind each of the front (2) 6mm screws there is a metal spacer and a retaining washer. Leave these spacers in the vehicle they will be reused.
3. Unbolt the panels from the inside of the drawer and remove them.
4. Fasten the Left #2 and Right #19 Panels to the drawer enclosure using (6) 5/16 x 3/4" Bolts #14.2 and (6) 5/16" Washers #14.1. (See Figure 1)
5. Install the Handle using (2) 1/4-20 Serrated Nuts #14.5.
6. Remove the Tuffy Drawer from the enclosure. To do this, pull the drawer out as far as it can go then locate the small black plastic stops visible on the ball bearing drawer slides. One of the black stops will need to be deactivated by pressing down and the other one pulled up. Be careful not to break plastic stops. While deactivating the stops pull the drawer out and the slides will separate. When you are finished installing your drawer, line up the slides and gently push the drawer back in.
7. Place the enclosure assembly in the deck of the FJ.
8. Install the #20 Right and #16 Left Front Panels using (10) 1/4-20 x 1/2" Screws #14.4 and (10) 1/4-20 Serrated Nuts #14.5. (See Figure 2) NOTE: If you have the OEM subwoofer do not use #20 Right front panel, use #22 SP bracket instead.

## **OPTIONAL SECURITY STEP**

9. As an optional security addition two more mounting fasteners can be added but require drilling two holes. To do this align the holes in the bottom of the vertical panels with the original holes in the FJ deck. Mark the holes to drill under each of the unused holes for (2) 5/16 x 1 1/4" Bolts #14.7 toward the rear of the vertical mounting brackets. (See Figure 2)

**WARNING!** Make sure there is nothing under the vehicle deck which could be damaged by the drill bit when drilling. Also, when drilling do not push the drill bit through any further than necessary after the hole has been made.

10. Drill out the two marked spots to 3/8" holes.
11. Line up the mounting holes in the vertical panels with the original holes in the FJ and fasten them to the drilled holes using (2) 5/16 x 1 1/4" bolts #14.7, (2) 5/16 Nylock nuts #14.9, and (4) 5/16" Washers #14.1. (See Figure 2)
12. Install the (4) 6mm x 25mm Screws #14.6 and (4) 1/4" Washers #14.8 in the original FJ holes to secure the enclosure assembly to the deck. (See Figure 2)

13. Install the #18 Right and #17 Left Lid Panels using (4) ¼-20 x 1 ¼ bolts #14.11, (4) Nylock nuts #14.10 and (12) ¼" Nylon Washers #14.12. Be sure to insert one nylon washer between each Lid Panel connection and the other mounting panel. Do not over tighten, the lid should pivot easily but not be so loose that it will rattle. (See Figure 1)  
NOTE: If you have the OEM subwoofer do not install #18 Right Lid Panel.
14. Gently reinstall the drawer into the enclosure. DO NOT FORCE IT OR THE DRAWER SLIDE BEARINGS WILL BE DAMAGED!
15. Check to make sure the Handle does not hit the rear door on the FJ and the rear seat latches into the upright position. To adjust the location, loosen the mounting hardware and maneuver it to the correct position then refasten the mounting hardware.
16. Tip: Place the carpet removed from the floor on top of the drawer to prevent surface scratches on the drawer.

**IMPORTANT!** If the jack has been left in the original location it is imperative that everyone who may need to use it becomes familiar with the procedure for removing it after the drawer has been installed. If anyone who will need to access the jack will not be able to remove the jack it should be relocated inside the drawer or another secure location. Do not store it or any other heavy objects in the storage under the side flaps they are not designed to retain items in an accident.

**FIGURE 1 (VIEW FROM REAR DOOR)**

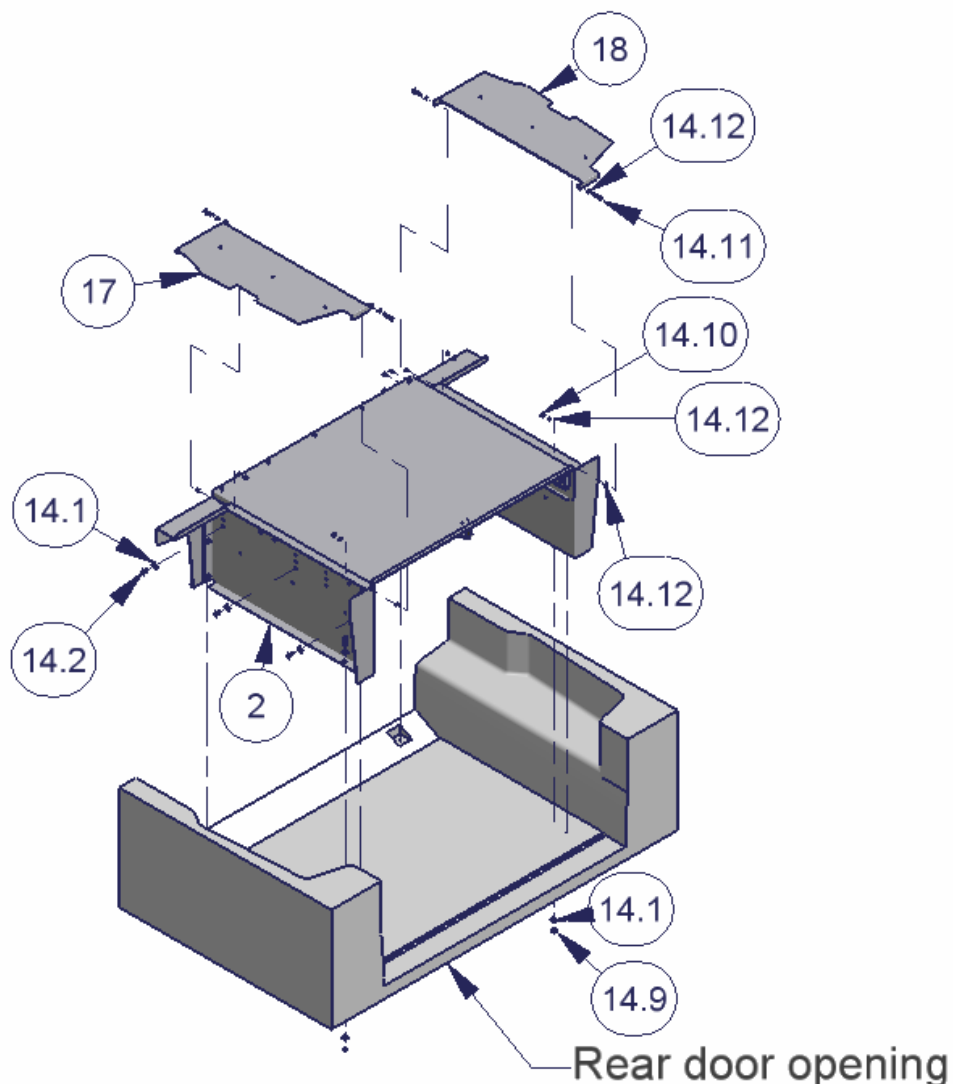

# FIGURE 2 (VIEW FROM INSIDE TOWARD REAR)

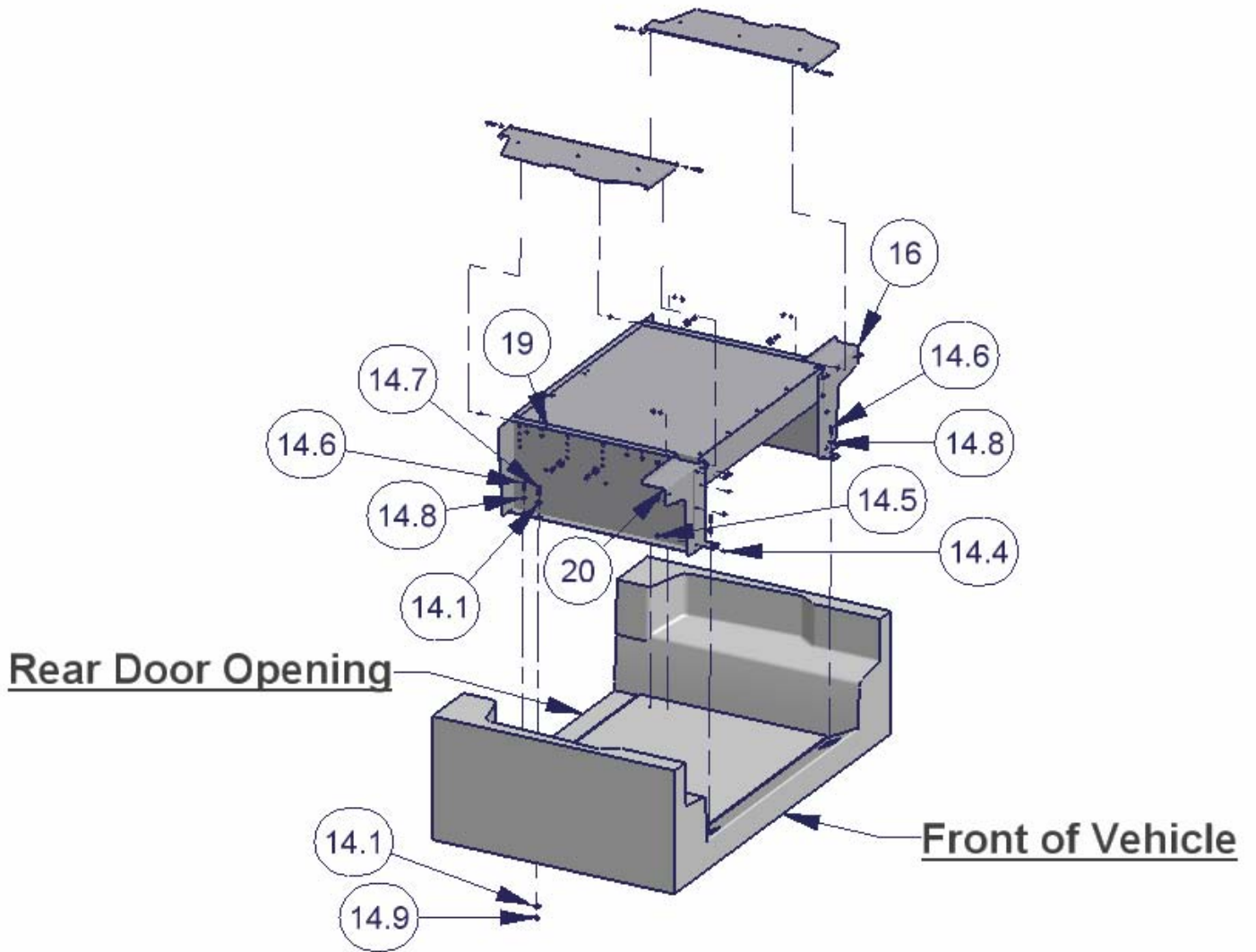

Call (970) 564-1762 for Technical Support