

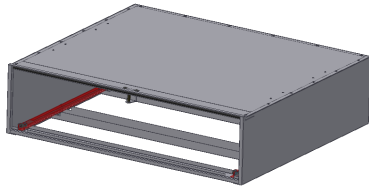

INSTALLATION INSTRUCTIONS

186 Ford Expedition Rear Cargo Drawer Mounting Kit
(This kit is designed to mount on the rear cargo drawer sold separately)
Please read and fill out the enclosed warranty registration card to activate your warranty.

Parts used which are included with the drawer assembly



Enclosure

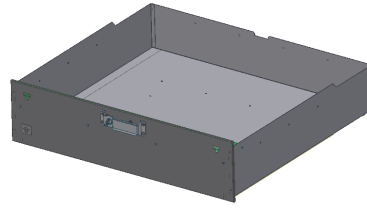

Drawer

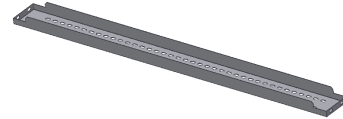

#8 (2) Mounting Brackets

186 Mounting Kit Parts

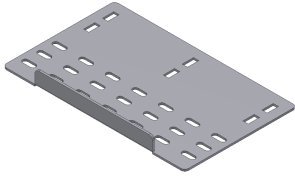

#5.1.1.4 (2) Support Plates

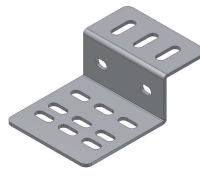

#5.1.1.2 (2) Short risers

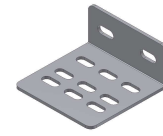

#5.1.1.5 (2) Short riser supports

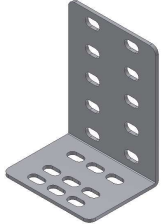

#5.1.1.1 (4) Upper tall risers

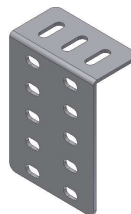

#5.1.1.3 (2) Lower tall risers

186 Shipping Package

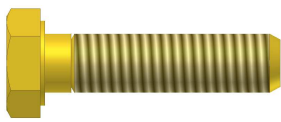

#5.1.1.6.4 (18) 5/16x1 1/4" Bolts

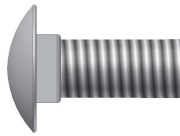

#5.1.1.6.2 (8) 5/16x7/8" Bolts

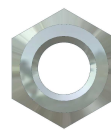

#5.1.1.6.3 (26) 5/16 Nuts

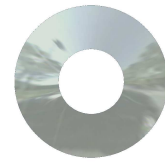

#5.1.1.6.1 (44) 5/16 Washers

Parts used from the drawer shipping package (Included with drawer)

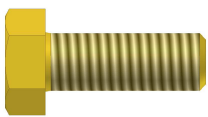

#5.2.4 (4) 5/16-18x7/8" Bolts

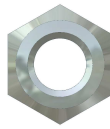

#5.2.2 (4) 5/16 Nuts



#5.2.3 (8) 5/16 Narrow OD Washers

Tools required

- 1/2" Shallow socket with a long extension and a ratchet (Universal joint also helps)
- 1/2" Wrench

WARNING! This drawer is rated to hold a maximum of 250# evenly distributed. The enclosure is rated to hold 250# on top evenly distributed. This would include any dividers mounted in the drawer. Never stand or sit on the Tuffy drawer or enclosure. The vehicle should not be operated with the drawer opened and not secured shut. The drawer should not be operated/opened when not level. Keep hands clear of moving parts and pinch points when maneuvering the drawer. Do not exceed the rated weight capacity for this product.

Mounting Directions

FOR SAFETY THE DRAWER REMOVAL REQUIRES AT LEAST (2) PEOPLE. THE DRAWER SHOULD ALWAYS BE EMPTY BEFORE REMOVING IT. CONSTANT SUPPORT MUST BE APPLIED TO HOLD UP THE FRONT OF THE DRAWER THROUGHOUT THE ENTIRE REMOVAL PROCESS SO IT DOES NOT CAUSE INJURY AND/OR DAMAGE.

1. Check the floor #5.1.1.6.5 and wheel well panels of the vehicle for cubby holes containing important gear or require access in an emergency (Jack, spare tire, spare tire access, fuses, etc.). If floor access is required make sure that it is exposed and accessible through the opening in the bottom of the drawer enclosure when the drawer is removed. Remove and relocate any inaccessible items as required.
2. The mounting bracket location measurements in these instructions are for a standard Ford Expedition rear tub configuration #5.1.1.6.5. Due to the wide variety of options, models, and other variables your vehicle may be different. If the dimensions in the vehicle where the drawer will be installed vary from the illustration shown in Figure 1 the dimensions for the mounting locations will need to be adjusted. The mounting system was designed to be flexible to accommodate a wide variety of mounting applications. (See Figure 1)

FIGURE 1

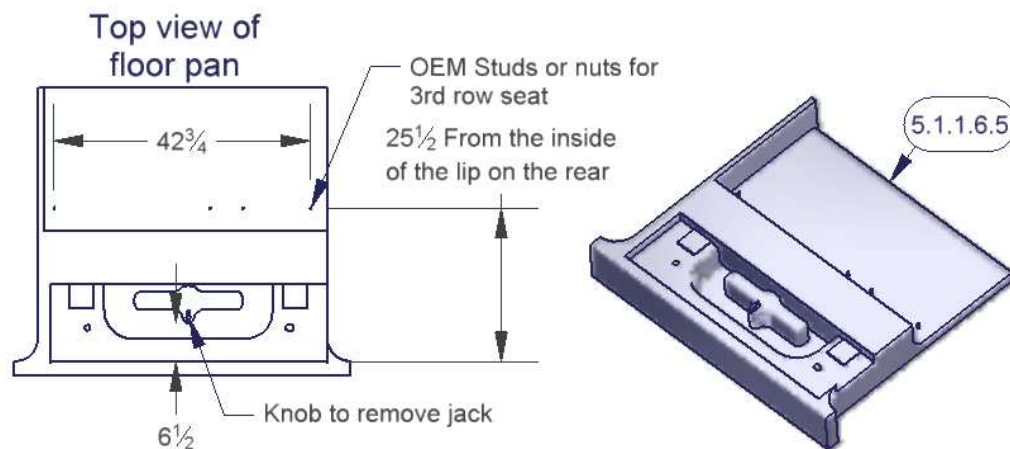

3. Remove the jack access cover (and the 3rd row seats or cover if applicable) but save the OEM mounting fasteners. Some of them will be reused.
4. Remove the drawer from the enclosure. Pull the drawer out until it stops. Lift up the front of the drawer and pull it out a few inches further until the stop bolts on the drawer slides clear the rollers on the enclosure slide. Pull the drawer again until it stops being sure to support the front of the drawer. Pivot the front of the drawer down and lift the rear end of the drawer out so the rollers on the drawer slides pull free through the slots in the enclosure slides. Reverse steps to install. (See Figure 2)

FIGURE 2

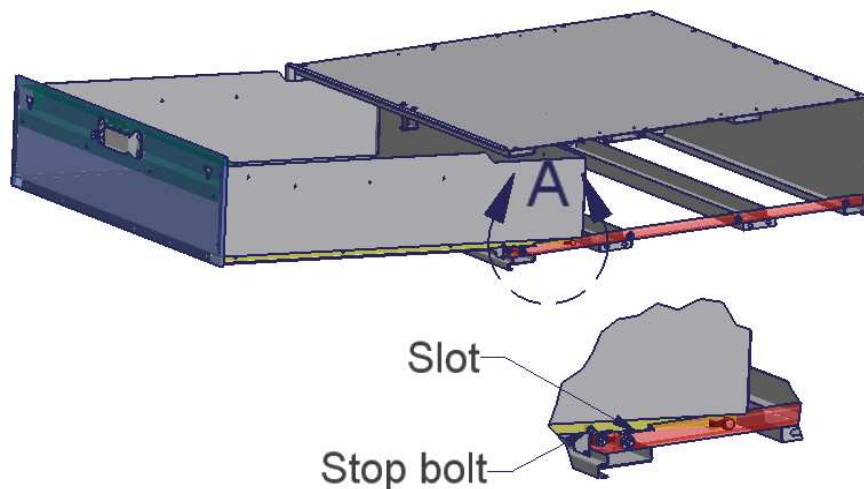

5. For a standard mounting application as described above fasten only (1) #8 mounting bracket to the drawer enclosure with the illustrated hardware. These bolts are difficult to reach; Use a 1/2" shallow socket with a long extension and a ratchet (Universal joint also helps) and a 1/2" wrench on the other end. Unbolting the slide using a 7/16" wrench will make things easier as well. **These parts and fasteners are included with the drawer.** (See Figure 3)

FIGURE 3

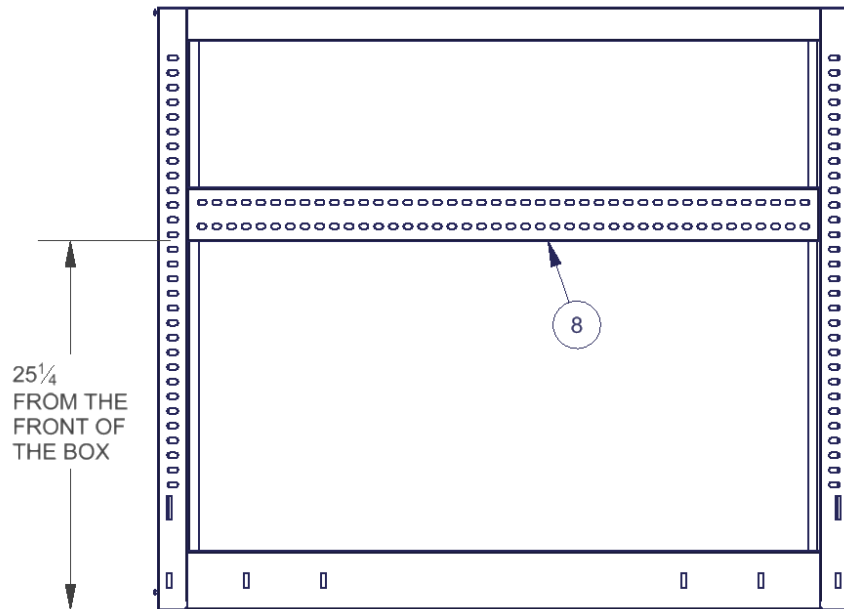
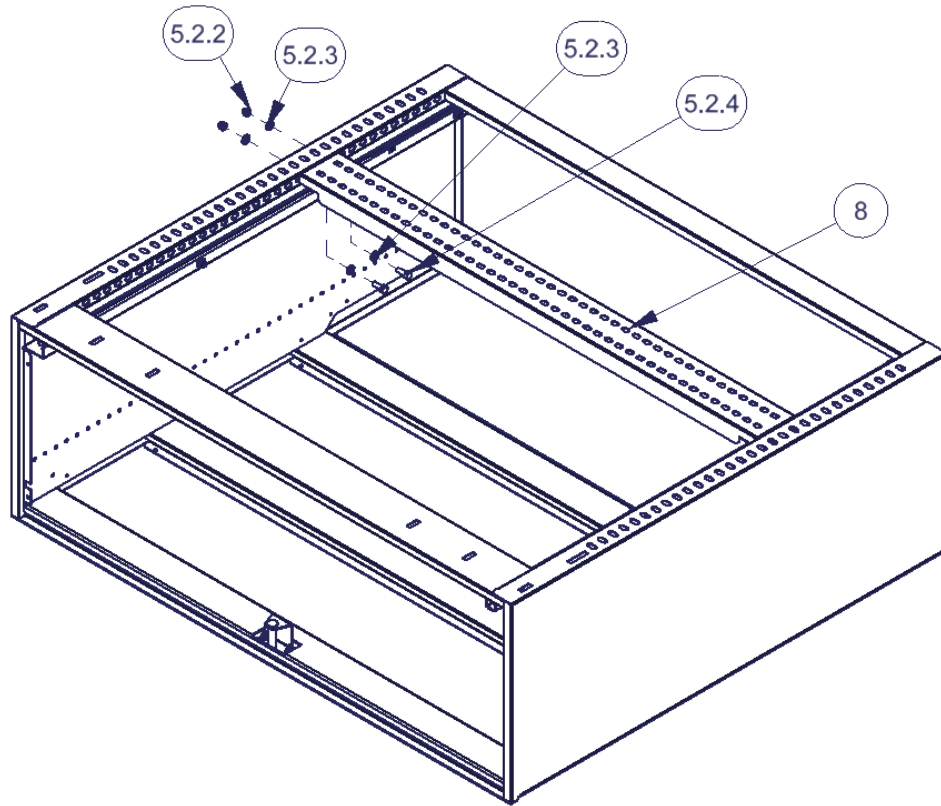

6. Assemble the mounting brackets as illustrated. Be sure the left and right sides are assembled opposite. (See Figure 4)

FIGURE 4

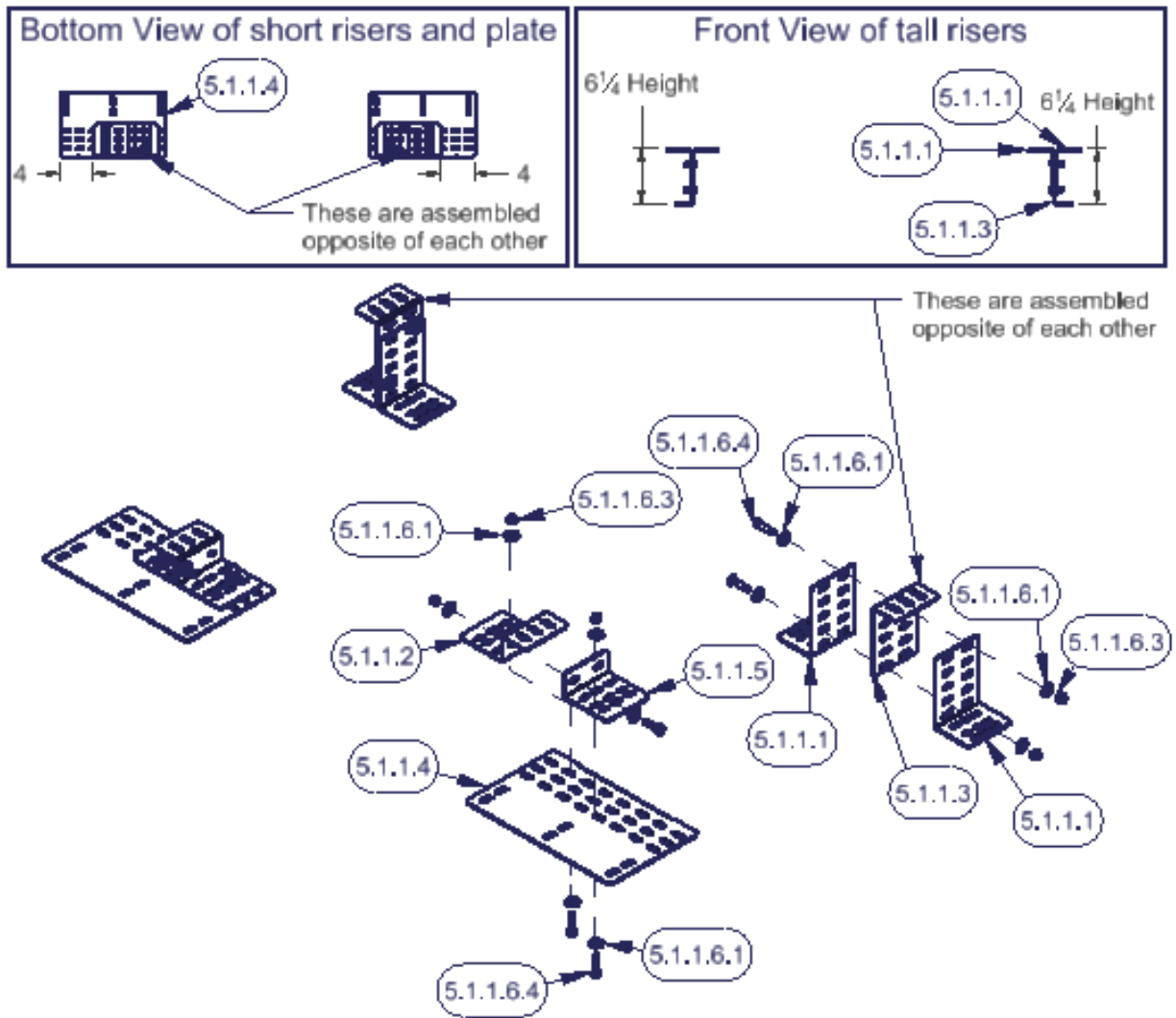

7. Fasten the assembled brackets to the bottom of the drawer enclosure with the hardware illustrated. Be sure they are oriented and located as shown for a standard installation. (See Figure 5)

FIGURE 5

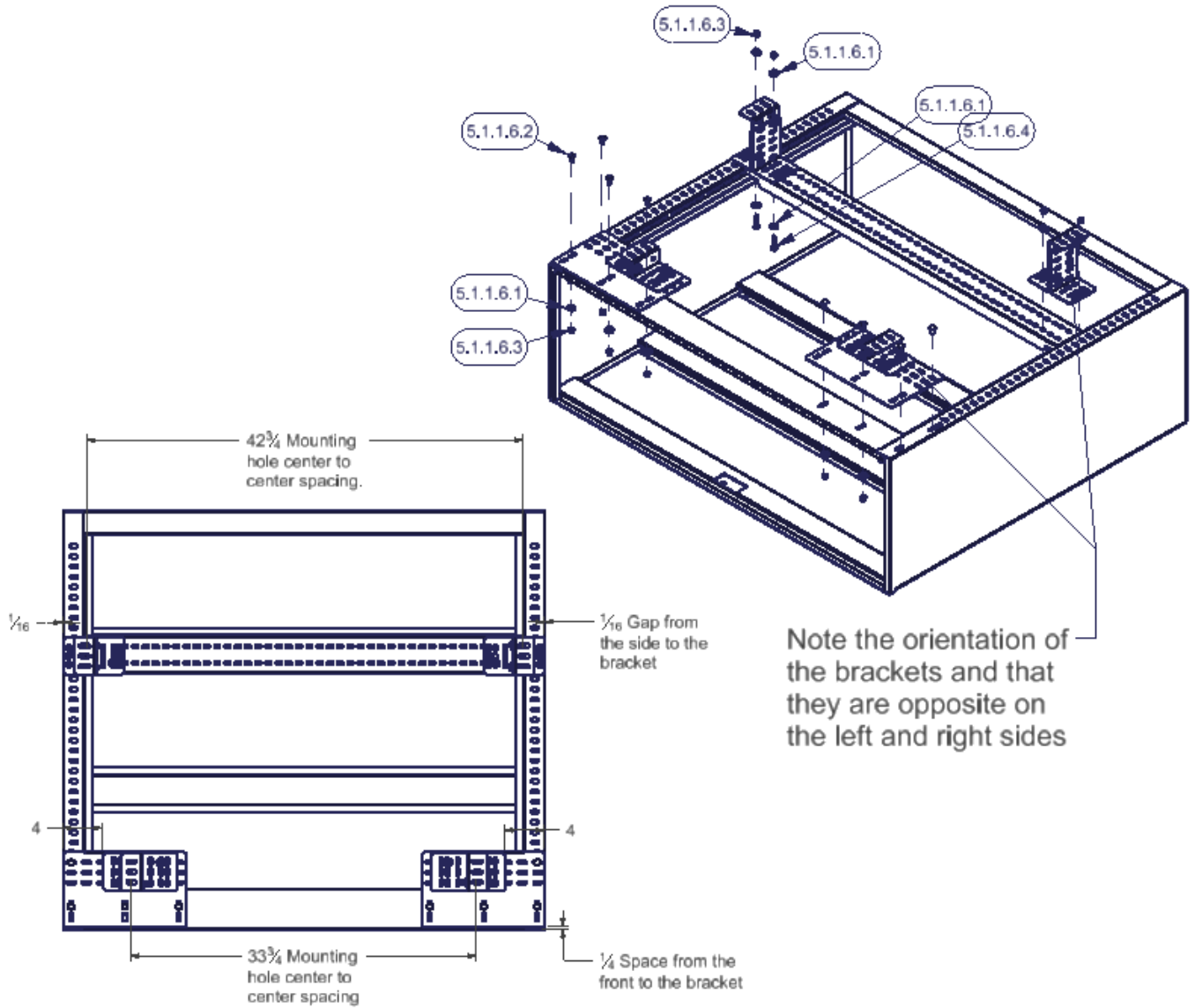

8. Place the enclosure with the mounting brackets in the rear of the vehicle. Be sure the correct holes in the longer mounting brackets #5.1.1.3 line up with the studs or nuts in the vehicle. The enclosure should overlap onto the rear sill by ¼". Check that the tailgate shuts with enough clearance for the drawer handle. **Make sure the jack can still be removed.** If these studs or nuts are not available drill holes in the vehicle tub which best correspond to the holes in the 5.1.1.3 Mounting brackets (See Figure 6)
9. Mark the spots under the illustrated holes in the #5.1.1.2 Mounting brackets for drilling. (See Figure 6)

Warning! Be sure there is nothing on the underside of the vehicle floor which will be damaged when drilling. Most vehicles have a gas tank and gas lines in that area.

10. Remove the drawer enclosure and drill out the marked spots to 3/8". (See Figure 6)
11. Fasten the enclosure with the brackets mounted to the floor of the vehicle as illustrated using the OEM hardware to the existing 3rd row seat studs or nuts. Or if the holes were drilled fasten with the provided #5.1.1.6.4 Bolts, 5.1.1.6.1 Washers & 5.1.1.6.3 Nuts through the drilled holes. (See Figure 6)

FIGURE 6

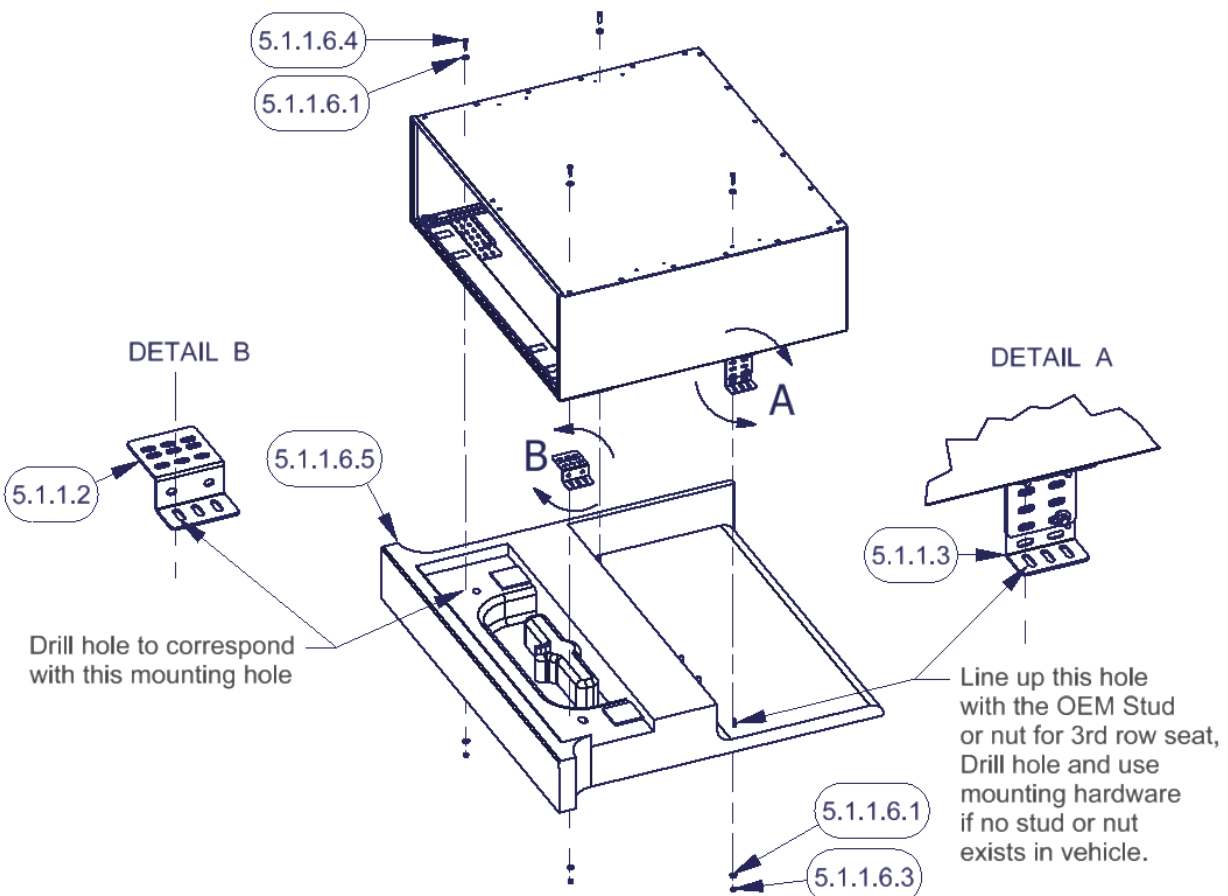

12. Insert the drawer and test the operation. Make sure there is clearance between the drawer handle and the rear tailgate. Test to make sure that access to any important compartments in the floor or side panels are maintained.

ATTENTION:

FREQUENT LUBRICATION IS NECESSARY ON THE LOCKING SYSTEM

The pushbutton lock contains an "O" ring seal to protect the interior from dust and water. If this mechanism is not lubricated regularly it will become difficult to operate and it may not return to its home position preventing the key from operating the lock. If this happens simply pull up on the pushbutton to manually bring it back to its home position. Lubricate the pushbutton with a light lubricant such as silicone spray. The pushbutton may have to be periodically disassembled and cleaned.

Call (970) 564-1762 for Technical Support